

USER'S MANUAL



V. BRØNDUM A/S
Item No.: A0800064



With HEPA filter and multi-tube filter for fine dust



With HEPA filter and fire-resistant filter for hot dust and ashes



RONDA[®] 5-58 Duo

Heavy Duty Industrial Vacuum Cleaner
For Mobile Wet/Dry Suction

IMPORTANT!

Read this manual before you operate the machine.

Intentionally blank page

USER'S MANUAL

Index

Description of the RONDA® 5-58 Duo	5
Technical data	6
Standard accessories with item numbers	7
Structure and description of the machine	8
Mode of operation	8
Motor top with suction motor, deflector/HEPA filter and standard filter	8
Collection container 2.....	9
Collection container 1 with float valve and coarse filter.....	9
Scope of application	10
Safety directions	10
Assembling	11
Start and suction of dry dust and liquids containing particles	12
Emptying	13
Ronda 5-58 Duo and Duo-R with multi-tube filter and HEPA filter.....	14
Vacuum indicator and filter cleaning during operation	16
Check and replacement of filters	17
Ronda 5-58 Duo and Duo-R with multi-tube filter and HEPA filter.	18
General information.....	18
Check and replacement of multi-tube filter.....	18
Replacement of HEPA filter	19
Check of the coarse filter in container 1	19
Disposal of used filters	19
Cleaning and maintenance	20
Maintenance of the motor top	21
Troubleshooting	22
Service and repair.....	24

USER'S MANUAL

Intentionally blank page

USER'S MANUAL

RONDA[®] 5-58 Duo

Heavy Duty Industrial Vacuum Cleaner for Large Quantities of Dust

Congratulations on your new RONDA[®] 5-58 Duo industrial vacuum cleaner from V. BRØNDUM A/S.

RONDA[®] 5-58 is a heavy duty industrial vacuum cleaner, which has been developed for the vacuuming of large quantities of dry dust and a combination of wet and dry. The machine separates the large particles and the liquid from the fine dust without the user needing to worry about changing the filters. The machine has been developed for the suction of dust, sludge and chips and is perfect for the suction of for instance large quantities of wood waste, chips and sawdust. Ronda[®] 5-58 Duo-R is made of fire-resistant and non-flammable materials and is perfect for large quantities of hot ashes and dust.

- 2,4 kW continuous suction power
- Cyclone separator
- Trolley frame with large wheels
- Very large collection capacity
- Degree of protection against moisture IPX4 (IEC 60 529)
- Diversion of static electricity
- Low noise level
- Easy detachable containers
- Perfect for wood waste and chips
- Obtainable with multi-tube filter and HEPA filter



RONDA[®] 5-58 Duo has 2 separator containers. Container 1 is a cyclone separator with a coarse filter and separates liquids, coarse particles, chips etc. larger than 1.5 mm. Only the finest dry particles will continue to separator container 2.



The standard version of separator container 2 is provided with a standard fabric filter, which holds back the small particles. For tasks with large quantities of fine dust the solution with the self-cleaning multi-tube filter is perfect.

In addition to the multi-tube filter and the pressure equalization valve for filter cleaning during operation separator 2 can be provided with a HEPA filter, which makes the machine suitable for the woodworking industry in cases where both wood chips and fine wood dust in large quantities are to be sucked up.

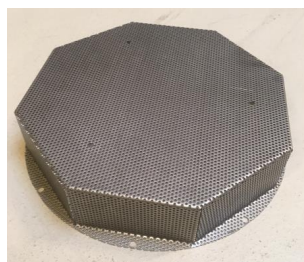

Ronda[®] 5-58 Duo-R is as standard equipped with a HEPA filter and with a multi-tube filter made of a fire-resistant material.

The prefilter of container 2 is a robust steel wire grating, which holds back the large particles. The separator containers of Ronda[®] 5-58 Duo-R are made of stainless steel, which makes the machine perfect for suction of large quantities of hot ashes and dust.

USER'S MANUAL

Technical Data

RONDA® 5-58 Duo is connected to 230 V mains voltage.

Check that the voltage and fuse of the power source correspond with the data mentioned on the data plate of the machine and with the technical data of this manual.

Below you will find the technical data of the machine.

Suction motor by-pass	2400	Watt
Suction motor voltage	230	Volt
Suction capacity	2400	mmWc
	23,5	kPa
Air volume, max.	120	l/sec
	432	m ³ /h
Noise level, 1 m	72	dB(A)
Noise level, 4 m	63	dB(A)
Collection container 1	58	l
Collection container 2	30	l
Height	920	mm
Height with multi-tube filter and HEPA filter	1150	mm
Length	1155	mm
Width	550	mm
Weight without accessories	45	kg
Number of suction motors	2	

USER'S MANUAL

Standard Accessories

RONDA® 5-58 Duo is supplied with a complete set of accessories comprising tubes, hose and all the necessary nozzles.

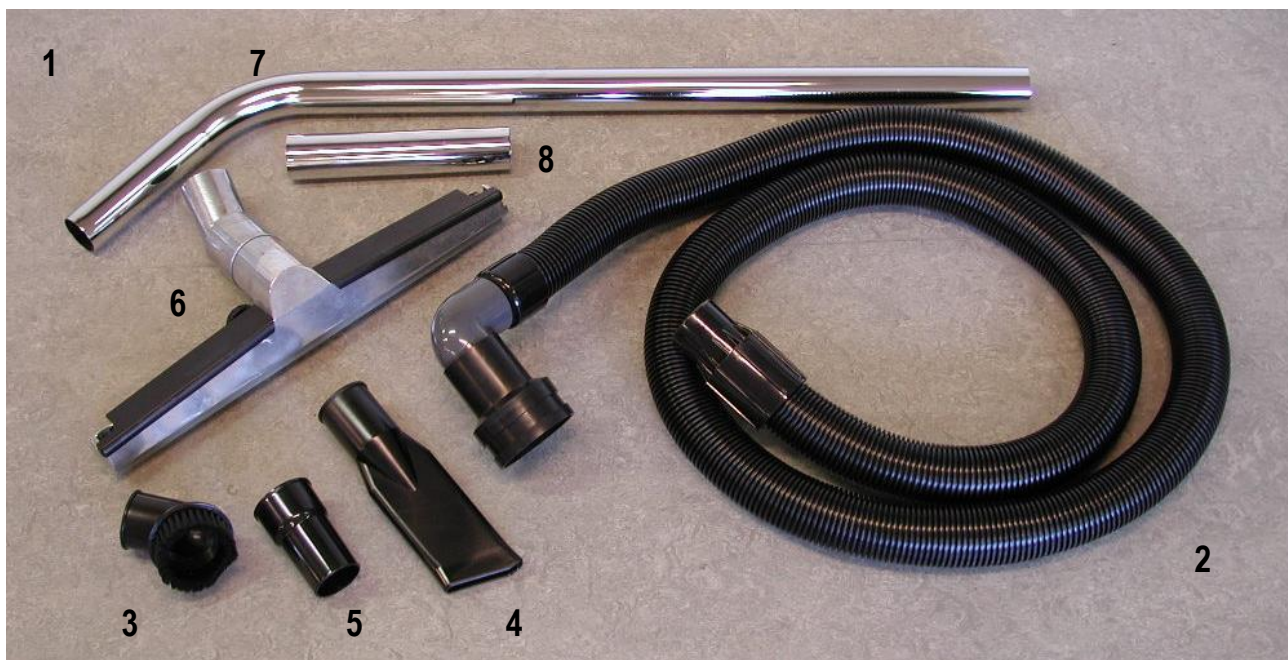

Please note that the plastic hose (position 2) is delivered without the angular bend for Ronda 5-58 Duo.

Accessories can be re-ordered on the item numbers below:

2. Plastic hose 6 m, Special superflex	84.54.5053
3. Round brush	80.34.5001
4. Crevice tool	80.34.5000
5. Adapter for round brush etc.	80.34.5002
6. Floor nozzle B-500 with wheels	84.38.5010
7. Tube with bend	80.52.5000
8. Short extension tube, 0.25 m	80.52.5020

USER'S MANUAL

Structure and Description of the Machine

RONDA® 5-58 is a heavy-duty industrial vacuum cleaner which has been developed for the vacuuming of large quantities of dust. A description of the structure and the main parts of the machine will follow below.

RONDA® 5-58 Duo has 2 separator containers.

Container 1 is a cyclone separator with a coarse filter, which separates all the particles such as chips etc. larger than 1.5 mm. Only the finest particles will continue to separator container 2. In Ronda® 5-58 Duo-R the coarse filter is made of steel wire mesh, which makes it very robust.

Container 2 contains a standard fabric filter but can be equipped with a multi-tube filter and a HEPA filter. The multi-tube filter in Ronda® 5-58 Duo-R is made of a fire-resistant material.



Mode of Operation

The dust caught will be brought into container 1 by the suction air, where the coarse filter will hold back the large particles.

The fine dust continues with the suction air through the connection hose to collection container 2, where the standard fabric filter holds back the fine particles.

Finally the air, which has now been purified, is conducted through the motor top and will leave the machine under the yellow motor top part.

Motor Top with Suction Motor, Deflector and Standard Filter

The motor top is provided with an integrated handle (1) and switches (2) to the suction motors. The deflector (3) keeps the standard filter stretched.

RONDA® 5-58 Duo-R and Ronda® 5-58 Duo with HEPA filter has no deflector.

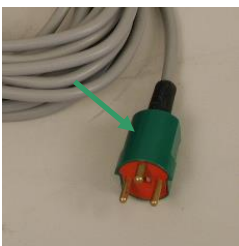

The suction of dry materials may form static electricity in hoses and tubes. Therefore the electric cable has a separate cable (conductor) for earth connection, which protects the user against the inconveniences in connection with static electricity.

USER'S MANUAL

IMPORTANT!

The motor top must not be covered when the machine is operating. If the air current from the suction motors cannot leave the machine there is a risk of the motor top being overheated and damaged.



The standard filter is held in place by the deflector under the motor top. The filter holds back the fine and smallest dust particles and protects at the same time the turbine blades of the two suction motors. The turbine blades may be damaged if there are wearing particles in the air current.

Collection Container 2

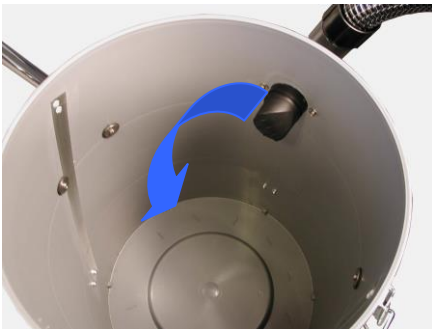

The collection container has also diversion for static electricity, and the oblique container connection piece ensures the cyclone effect in the container.

The material sucked up will fall to the bottom of the container, which has a large collection capacity.

Collection Container 1 with Float Valve and Coarse Filter



The lid of container 1 is secured with two container clips and is provided with a float valve (1), which ensures that the container will not be filled to overflowing with liquid.

The large connection piece for injection (2) in container 1 has been tilted, which gives a cyclone effect so that the material sucked up will settle at the bottom of the container.



The pre-filter is placed immediately under the lid and is held in place by the float valve.

The filter holds back the coarse particles.

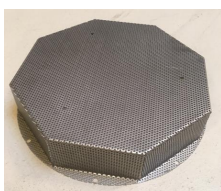
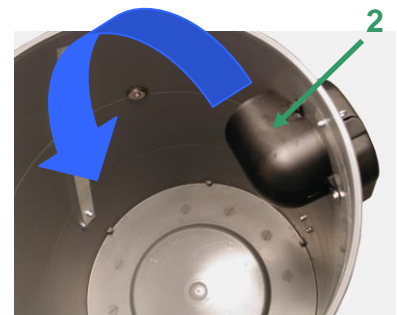

In Ronda[®] 5-58 Duo-R the pre-filter is made of wire netting, which makes it very robust. As Ronda[®] 5-58 Duo-R must not be used for suction of liquids, there is no float valve.

USER'S MANUAL

Scope of Application

RONDA® 5-58 Duo is a vacuum cleaner according to DS/EN 60335-2-2 and CEI/IEC 60335-2-69 and may only be used as such. RONDA® 5-58 Duo may be used for the suction of liquids containing particles.

RONDA® 5-58 Duo must not be used for the suction of dust hazardous to health according to CEI/IEC 60335-2-69 Annex AA or for the suction of hot, sour or basic liquids or liquids with a high concentration of small and wearing particles. Suction of strongly wearing, small particles will shorten the life of the machine.

RONDA® 5-58 Duo is not approved for the suction of inflammable, explosive, poisonous or other kinds of dust, liquids or gases, which are extremely hazardous to health, and must therefore not be used for these purposes.



Safety Directions

- The machine is not approved for inflammable, explosive, poisonous or other kinds of dust, liquids or gases, which are extremely hazardous to health.
- The user must make sure that the machine is adjusted to the task, and that the requirements of the authorities are met.
- Avoid damaging the electric cable. In case of replacement of the electric cable only an original electric cable must be used. The replacement has to be done by a professional.
- The machine is to be connected to mains voltage with a reliable earth connection (Active protection against contact).
- Before any repair or maintenance of the machine – also cleaning – the plug must be removed from the power source.
- RONDA® 5-58 Duo is connected to 230 V mains voltage. Check that the voltage and fuse of the power source correspond with the data of the data plate of the machine and with the technical data of this manual.
- This machine is also suitable for commercial use, for example in hotels, schools, hospitals, factories, shops, offices, rental businesses and for other than normal housekeeping purposes.
- Guidelines in Connection with Disposal of the Machine



The product you have purchased is subject to Directive 2002/96/EC of the European Parliament and the Council of the European Union on waste electrical and electronic equipment (WEEE) and should not be disposed of as unsorted municipal waste. Please utilize your local WEEE collection facilities in the disposition of this product and otherwise observe all applicable national requirements.

If the use, safety or construction of this machine raises any questions, please do not hesitate to contact either your dealer or V. BRØNDUM A/S.

USER'S MANUAL

Assembling



- Unpack your RONDA® 5-58 Duo and check that all the parts ordered are present.
- Assemble the 2 parts of the tube and mount the nozzle or another piece of accessory on the tube.
- Fasten the rubber coupling of the suction hose to the tube and put the other connection piece (Ø 90 mm) of the suction hose into the container coupling on top of the lid of container 1.
- Check that the collection containers are empty and that the filters are placed correctly in the collection containers. Check that the filters of the machine are

intact and undamaged. (See the chapter concerning replacement of filters).

- Check that plug and lead are undamaged before the plug is connected to a power source. If the lead or the plug is damaged, a professional must replace the parts.
- Connect the machine to 230 V mains voltage with a reliable earth connection (Active protection against indirect contact).

RONDA® 5-58 Duo can now be used for suction. The suction is described more precisely in the following chapter.

USER'S MANUAL

Start and Suction of Dry Dust and Liquids Containing Particles

During operation RONDA[®] 5-58 Duo can be wheeled on the large wheels and the swivel wheels mounted on the trolley.

When the machine has been correctly assembled and connected, it can be started at the switches of the motor top (1).



The two suction motors have a switch each (1). If delicate surfaces are to be vacuumed, you can reduce the suction power by using one motor only. In this way the air velocity is reduced.

The easiest way to vacuum large surfaces is to use the large brush nozzle with wheels. The nozzle is suitable for suction of dust and liquids from large, even surfaces. When the nozzle is passed over the even surface the particles are sucked up by the strong air current.

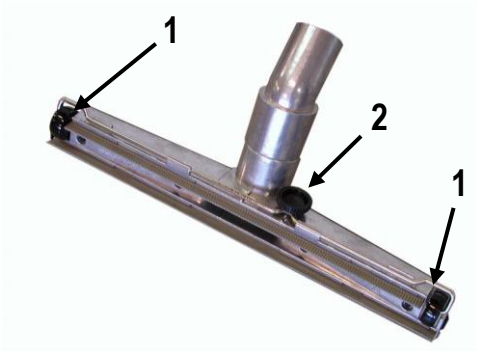

The floor nozzle is equipped with two wheels (1), which keep the nozzle at the same height over the floor.

In order to obtain an effective suction the brushes must be placed in the correct height over the floor. The height is adjusted at the knob (2) of the nozzle.

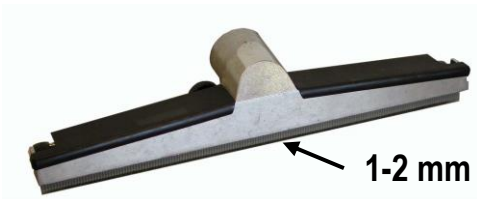

Adjust the height of the brushes over the floor to 1 to 2 mm.

The brushes are made of robust material, but they will gradually be worn. As the brushes are worn, it will be necessary to adjust the height of the brushes over the floor.

USER'S MANUAL

Emptying



Release the lid of container 1 by loosening the two container clips that secure the lid.

Lift the lid away and place it on an even surface.



Lift the coarse filter out of container 1. Lift the filter in the black mounting ring. Place the filter on a clean surface.

On Ronda® 5-58 Duo-R the coarse filter has been fastened in the lid of container 1.



Release container 1 by loosening the three clips that secure the container to the trolley frame.

The container can now be lifted off and emptied.



Empty container 2 by first removing the motor top. Loosen the two container clips securing the motor top on top of container 2.

Place the motor top on a dry, even and clean surface.



Lift the standard filter/multi-tube filter out of container 2. Remove the filter from the container by lifting in the black mounting ring. Use the two black lifting handles at the top of the filter plate to remove the multi-tube filter.

Place the filter on a clean and dry surface.



Release container 2 by loosening the three clips that secure the container to the trolley frame.

The container can now be lifted off and emptied.

USER'S MANUAL

Ronda® 5-58 Duo and Duo-R with Multi-Tube Filter and HEPA filter

RONDA® 5-58 Duo can be delivered with a complete filter system for the suction of fine, dry dust. The filter system consists of a pre-filter, a multi-tube filter and finally a HEPA filter. Ronda® 5-58 Duo-R is as standard equipped with a HEPA filter and a multi-tube filter in a fire-resistant material.

NOTE:

If RONDA® 5-58 Duo is equipped with a multi-tube filter and a HEPA filter, the machine must not be used for the suction of liquids as the filters may be damaged. **Ronda® 5-58 Duo-R must not be** used for the suction of liquids either.

1: The pre-filter is placed in container 1 and is secured on a black mounting ring placed immediately under the lid of the container. The float valve, which is mounted at the lid of the container, keeps the filter stretched.

2: The large multi-tube filter is placed in container 2. The surface of the filter is Teflon-coated which reduces the risk that particles will clog the filter. The filter is built up in tube elements, which are each stretched by a spring. This gives the filter a self-cleaning effect during operation.

3: The HEPA filter holds back the smallest particles and is mounted immediately under the motor top.

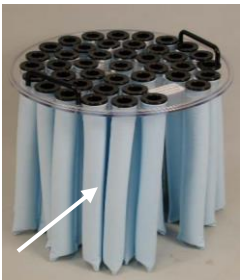

The large multi-tube filter in RONDA® 2-58 Duo is mounted in container 2. The multi-tube filter has been tested with quartz-dust-particles of which more than half is less than 5 µm. (5 µm correspond 0.005 mm.) The filter holds back 99.97% of all the particles, which corresponds to an emission of 0.06 mg/m³ in the purified air.

The surface of the filter is 18,650 cm² and is coated with a fine Teflon coating. The Teflon coating repels the dust, which therefore does not easily stick in the filter material.



The filter consists of a large number of tubes mounted on springs. During operation the tubes move, and some of the dust that can stick to the surface of the filter will fall down into the collection container.

The multi-tube filter in Ronda® 5-58 Duo-R is made of a fire-resistant filter material.

USER'S MANUAL



The motor top is provided with a HEPA filter of the finest dust-class "H".

The filter holds back the fine and smallest dust particles, which have not been held back by the multi-tube filter. The filter holds back the particles of $0.3 \mu\text{m}$ (0.0003 mm). The surface itself of the filter is 2.2 m^2 and is protected by a metal grid.

It is advisable always to let the machine rest for a few minutes before emptying it. The dust will fall to the bottom of the container, and the risk of whirling dust out into the environment during emptying is reduced.

NOTE:

The manometer of RONDA[®] 2-58 Duo has been calibrated to correct indication when the machine is used with the standard equipment (50 mm). If a hose or accessories with a smaller diameter are used, the manometer will show too much. If you want to be completely sure that the air velocity in the tubes and hoses is sufficient, the filter ought to be cleaned and, if necessary, the machine emptied, if the pointer of the manometer comes into the red field.

USER'S MANUAL

Vacuum Indicator and Filter Cleaning during Operation

The vacuum indicator placed on the adapter ring measures the vacuum between the filters of the machine during operation.

If the multi-tube filter is blocked by fine particles, the air pressure in the machine will fall. This will be indicated by the vacuum indicator. The pointer of the vacuum indicator reaching the read area indicates that the air velocity in the hose and in the tube is too low, and that the multi-tube filter therefore needs to be cleaned.

The multi-tube filter can be cleaned during operation, i.e. while the machine is working.

- Remove the hose from the tube.
- Block the suction of the hose so that full vacuum is made.

Vacuum will now be formed inside the machine and in the hose. At the same time the springs of the multi-tube filter will contract a little.

- Pull the flap of the shock valve (a regular pull, not a tug)

The equalization air will now go through the multi-tube filter in the opposite direction in order to equalize the pressure in the collection container and in the hose.

In this way the multi-tube filter is cleaned in an effective way. You can see the effect of the cleaning when you read the vacuum indicator.

Repeat the process a few times, if necessary, and read the effect on the vacuum indicator.

It is recommended to leave the machine for a few minutes before emptying it. The dust will fall to the bottom of the container, and the risk of swirling dust into the surroundings during the emptying is reduced.



USER'S MANUAL

Check and Replacement of Filters

The standard filter is placed in the container just under the motor top of the machine and holds back the fine particles.

The filter is made of robust filter cloth, but it will gradually be worn, and holes in the filter cloth may arise. The easiest way to check the filter for damages is to inspect the inside of the filter. If there are dust particles here, it is a sign of a damaged filter, which must be replaced.

IMPORTANT!
The machine must not be connected to the mains supply during maintenance and cleaning.



- Switch off the machine and pull the power supply plug out of the socket.
- Dismount the motor top of the machine by loosening the two container clips of the collection container (1).
- Lift up the motor top in the handle (2) and place the motor top carefully on a clean and even surface. Be careful about the deflector under the motor top.



- Inspect the inside surface of the standard filter. If there are dust particles on the inside surface of the filter, it is a sign that there are holes in the filter cloth.
- If there are holes in the filter cloth, the filter must be replaced.

The coarse filter is placed in container 1 and is checked in the same way as the standard filter.



- Loosen the clips that secure the lid, and lift off the lid of the container.
- Check the inside surface of the filter. If there are dust particles on the inside surface, it is a sign that there are holes in the filter cloth.
- If there are holes in the filter cloth, the filter must be replaced.

USER'S MANUAL

Ronda® 5-58 Duo and Duo-R with Multi-Tube Filter and HEPA filter

General Information

When replacing the filters you must take the necessary precautions in order to protect the environment and the respiratory passages of the operator. This protection depends on the tasks, for which the vacuum cleaner has been used, and the dangerousness of the dust and sludge on the surface of the filters. Before the filters are checked or replaced, the multi-tube filter must be cleaned as previously described, and the machine must be emptied.

Check and Replacement of Multi-Tube Filter (Item No. 84.67.1098)

The multi-tube filter is made of robust filter material and has a very long life. The filter will, however, gradually be worn because of the many large and small particles, which are held back. Therefore it must be checked regularly whether the multi-tube filter is undamaged and without holes.

If holes are worn in the filter material, the multi-tube filter cannot hold back the dust particles, which will continue through the filter and be caught by the HEPA filter. The HEPA filter is intended for very fine dust and will quickly be clogged, if the multi-tube filter is damaged.



- Release the motor top by loosening the container clips of the motor top.
- Place the motor top on a dry, clean and even surface.
- Inspect the upper surface of the multi-tube filter for dust particles. If dust particles are visible here, it indicates that the multi-tube filter is damaged, and that a hole has been worn in the filter material.

If the multi-tube filter is damaged or the surface of the filter has holes, the multi-tube filter must be replaced.

The procedure is the same for Ronda® 5-58 Duo-R. The multi-tube filter of Ronda® 5-58 Duo-R can be reordered on item No. 84.67.3010.

A replacement of the multi-tube filter should include a replacement of the HEPA filter as well. See the next chapter.

USER'S MANUAL

Replacement of the HEPA filter (Item No. 84.67.5007)

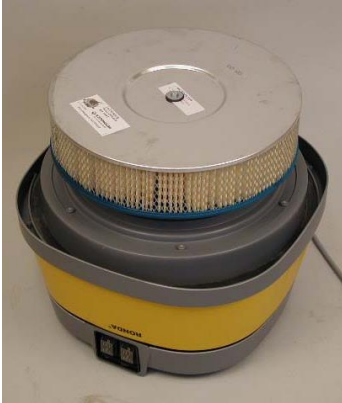

- Dismount the motor top by loosening the two container clips that hold the motor top. Place the motor top in such a way that there is access to the filter.
- Loosen the bolt, which secures the filter. The filter can now be lifted up, and you can dispose of the filter.
- Mount the new filter on the motor top, as you make sure that the contact surface of the filter is undamaged and clean.
- Tighten the bolt so that the filter is closely fitting and has a firm connection to the contact face in the motor top. Don't tighten the bolt too much.

Check of the Coarse Filter in Container 1



- Release the lid of container 2 by loosening the two clips securing the lid to the container.
- Lift up the lid and place it carefully on an even surface. Be careful about the float valve under the lid.



- Inspect the inside surface of the coarse filter. If there are large dust particles on the inside surface of the filter, it indicates that holes have been worn in the filter cloth.

The filter is to be replaced if there are holes in the filter cloth.

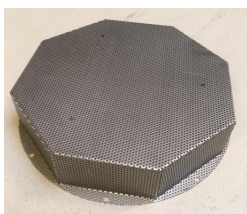

- The wire grating in Ronda® 5-58 Duo-R is extremely robust and has a very long life. Check that the grating is intact and clean it with a brush, if necessary.

Disposal of Used Filters

When disposing of the used filters you must make sure that this is done in accordance with the requirements of the Authorities of the Environment.

USER'S MANUAL

Cleaning and Maintenance

IMPORTANT!
The machine must not be connected to the mains supply during maintenance and cleaning.

Every time the machine has been used for suction of liquids it must be cleaned. If the machine is left with dirty water in container 1, there is a risk of formation of germs in the rotting water.

The easiest way to clean the container is as follows:



- Remove the suction hose connecting the two containers.
- Loosen the two clips securing the lid of the container.
- Place the lid of the container on an even surface.



- Take the coarse filter out of the container.
- Rinse the coarse filter with plenty of water.
- Let the water stream from the inside and out.

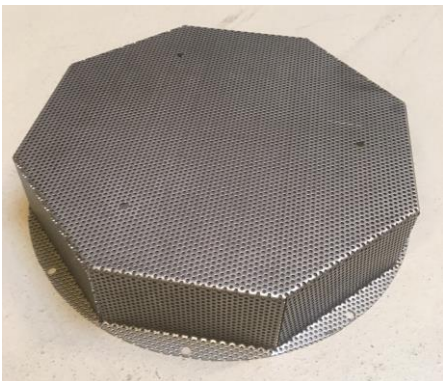

- The coarse filter of Ronda® 5-58 Duo-R is made of wire netting.
- The coarse filter is attached to the container lid.
- Clean the filter with a stiff brush.



- Release container 1 by loosening the container clips, which secure the container to the trolley frame.
- Rinse away sticking particles and other impurities in the container with clean water.

USER'S MANUAL

Maintenance of the Motor Top

The motor top is made of maintenance-free parts, and the daily maintenance is therefore limited to outside cleaning and inspection of the electric cables, switches, plugs and sockets for damages.

The easiest way to clean the motor top is with a moist cloth.

Please note: Aim no jets of water direct at the motor top!

To avoid stop in operation it is recommended that an authorized technician checks the electric parts once a year.

It is recommended that an authorized service centre checks the brushes of the suction motors after approx. 800 hours of operation and, if necessary, changes them. This prolongs the life of the suction motors.



Standard motor top



Motor top with HEPA filter

USER'S MANUAL

Troubleshooting

If the Machine Does Not Suck Up in a Satisfactory Way:

- The suction hose, tube or nozzle may be blocked.
Stop the machine and remove the blocking.
- Collection container 2 may be filled to overflowing. The float valve is designed to protect the suction motors by blocking the air to the motors when collection container 2 is filled with liquid.
Stop the machine and empty the container of liquid.
- The coarse filter may be blocked.
Take out the coarse filter and rinse with large quantities of clean water, so that any sticking particles will be removed. (See the chapter concerning emptying). Rinse with large quantities of clean water by conducting the water in the opposite direction of the normal flow direction of the air.

Ronda 5-58 Duo with Multi-Tube Filter and HEPA Filter:

- The collection container may be filled to overflowing.
Stop the machine and empty the container.
- A leak may occur in connection with the mounting of the motor top or the collection container.
Start the machine and block the suction hose. A possible leak can normally be heard. Loosen the container clips of the motor top or the collection container, place the motor top or the collection container correctly, and lock the clips again.
- The multi-tube filter may be blocked.
Clean the multi-tube filter as described in the chapter concerning cleaning of filters during operation.
- The HEPA Filter may be blocked.
Replace the filter as described in the chapter concerning replacement of filters.

Intentionally blank page

USER'S MANUAL

Service and Repair

Service and repair are free of charge within the warranty period (invoice must be presented) on the following conditions:

- The defect is caused by a design fault or defective material. (Normal wear and tear, misuse and insufficient maintenance are not covered by the warranty).
- No repair attempts have been made by parties other than V. BRØNDUM A/S, or authorized service centres approved by V. BRØNDUM A/S for warranty repairs.

Service and repair free of charge includes the replacement of defective parts and also the related costs.

The machine is handed in through the dealers of V. BRØNDUM A/S or sent direct carriage paid to:

V. BRØNDUM A/S
Sadolinsvej 14-16
DK-8600 Silkeborg

Tlf.: (+45) 8682 4366
Fax: (+45) 8680 3363
E-mail: v@broendum.com
www.broendum.com

V. BRØNDUM A/S reserves the right to introduce changes without further notice.